

# Study of a Mechatronic Valve Model for the Automotive Industry

Christian Meise<sup>1</sup>, Peter Oehler<sup>1</sup>, Stefan Breitschuh<sup>2</sup>,  
Wolfgang Fey<sup>1</sup>, Günter Schmitz<sup>2</sup>

<sup>1</sup>Continental Teves AG oHG

<sup>2</sup>Aachen University of Applied Science (FH-Aachen)

## Multi-Domain Simulation Scenario

The complexity of systems in the Automotive Industry increases day by day. Due to this, and the fact that modern products are based on advanced elements like Embedded Systems, which cannot effectively be designed without simulation techniques, motivates the development of a mechatronic valve model

### Motivation to generate a Mechatronic Valve Model

- ☐ Decreasing hardware iterations
- ☐ Shorten development time
- ☐ Shorten development costs
- ☐ Improve design solution
- ☐ Easier communication flow

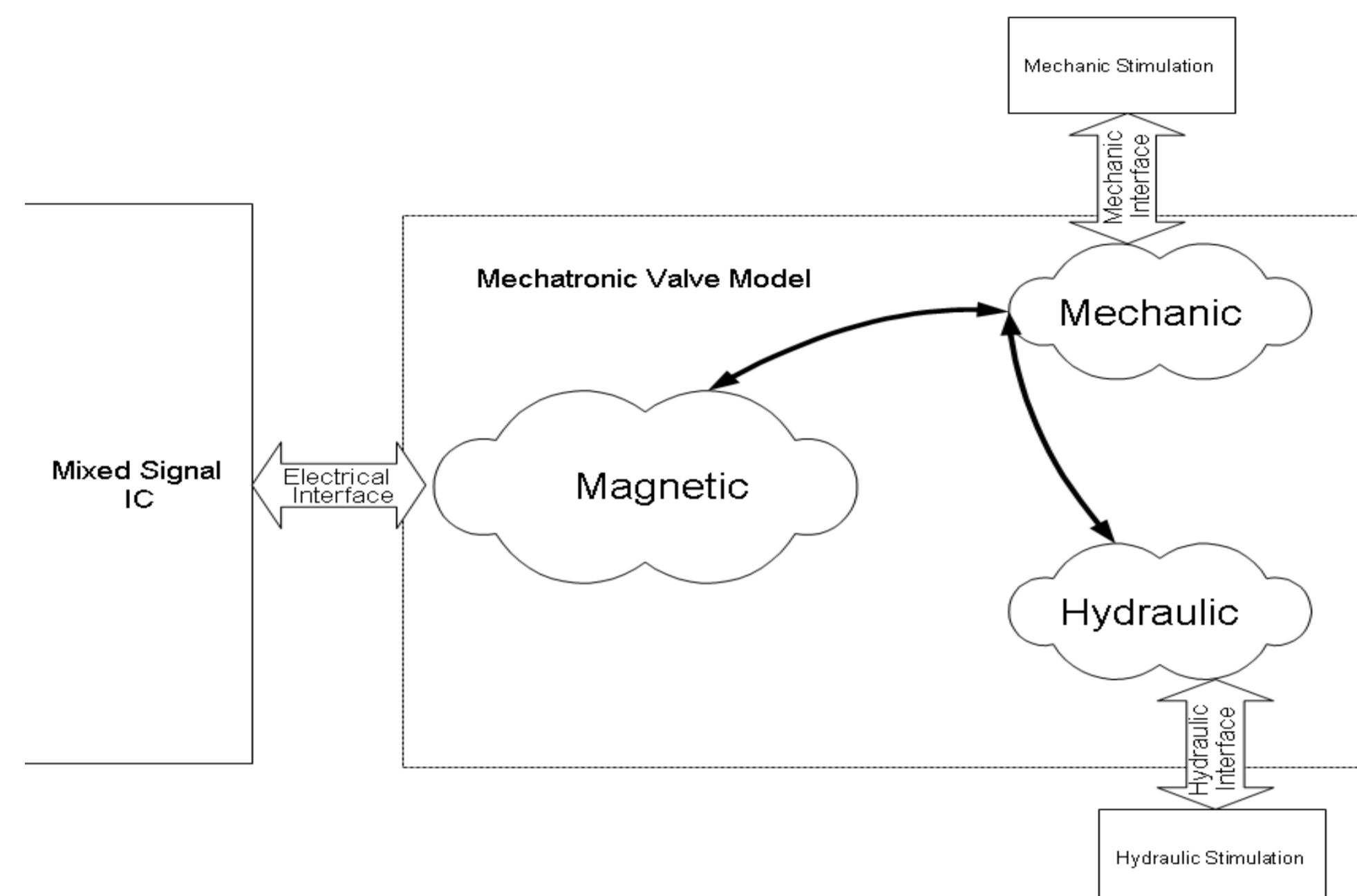

## The Mechatronic Valve Model

- More physical effects necessary than in a simple representation
- For example: ☐ Iron core + Mechanical movement  
☐ Hydraulic and thermal effects
- Splitting into different physical domains ("views")

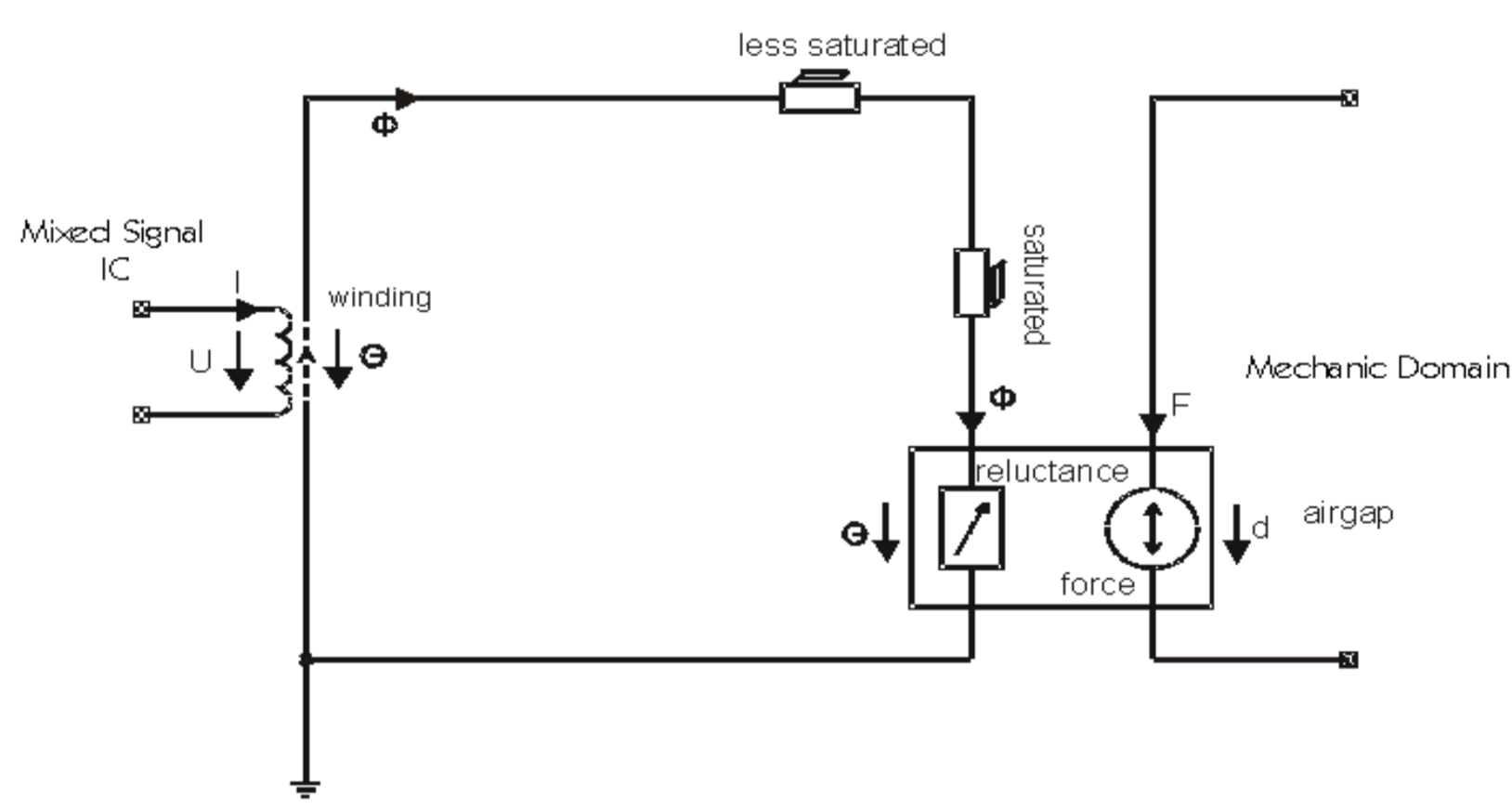
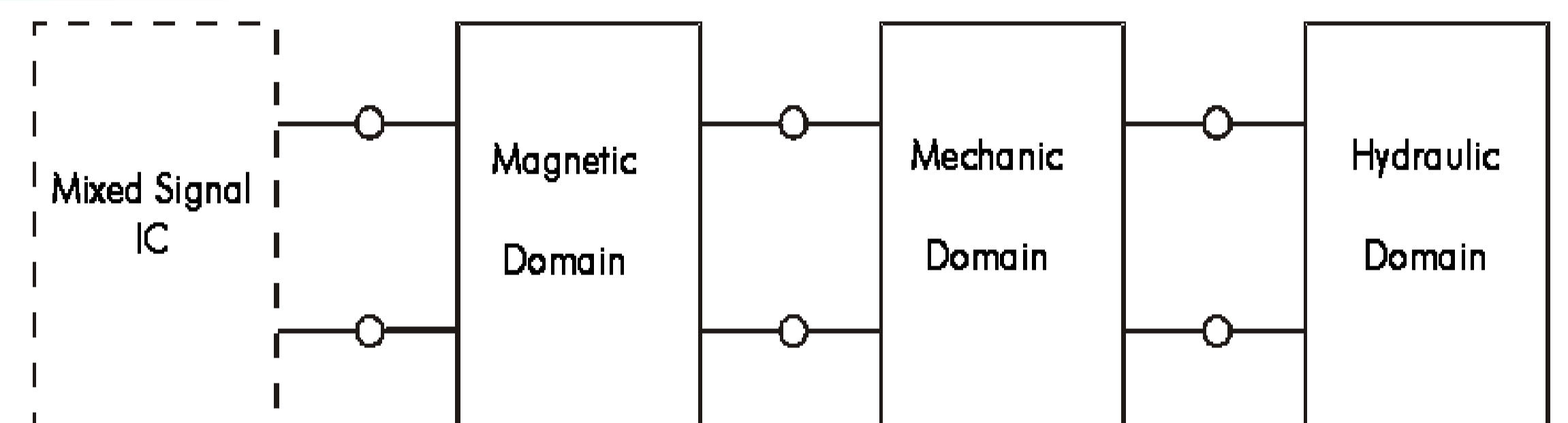

Magnetical Domain

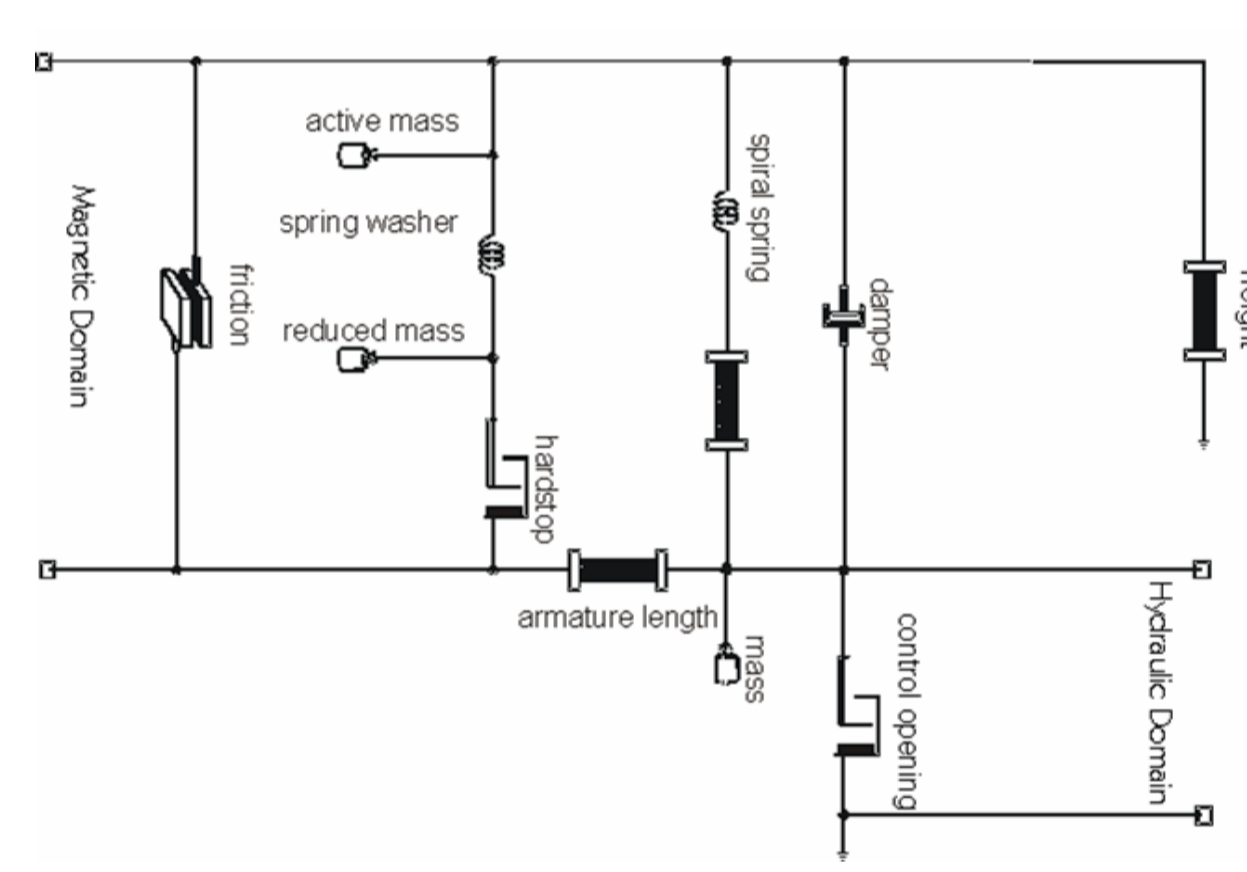

Mechanical Domain

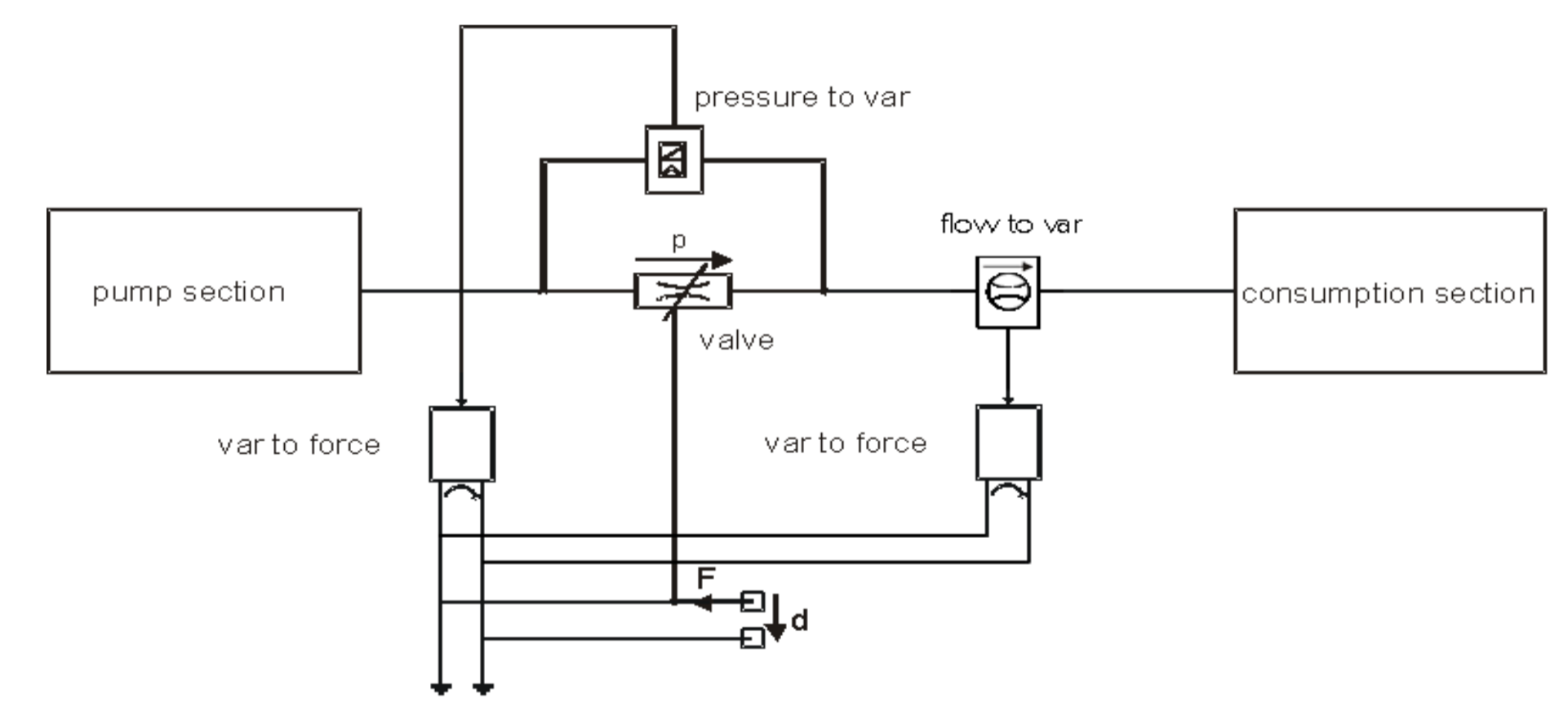

Hydraulik Domain

### Closed Loop Valve Stimulation

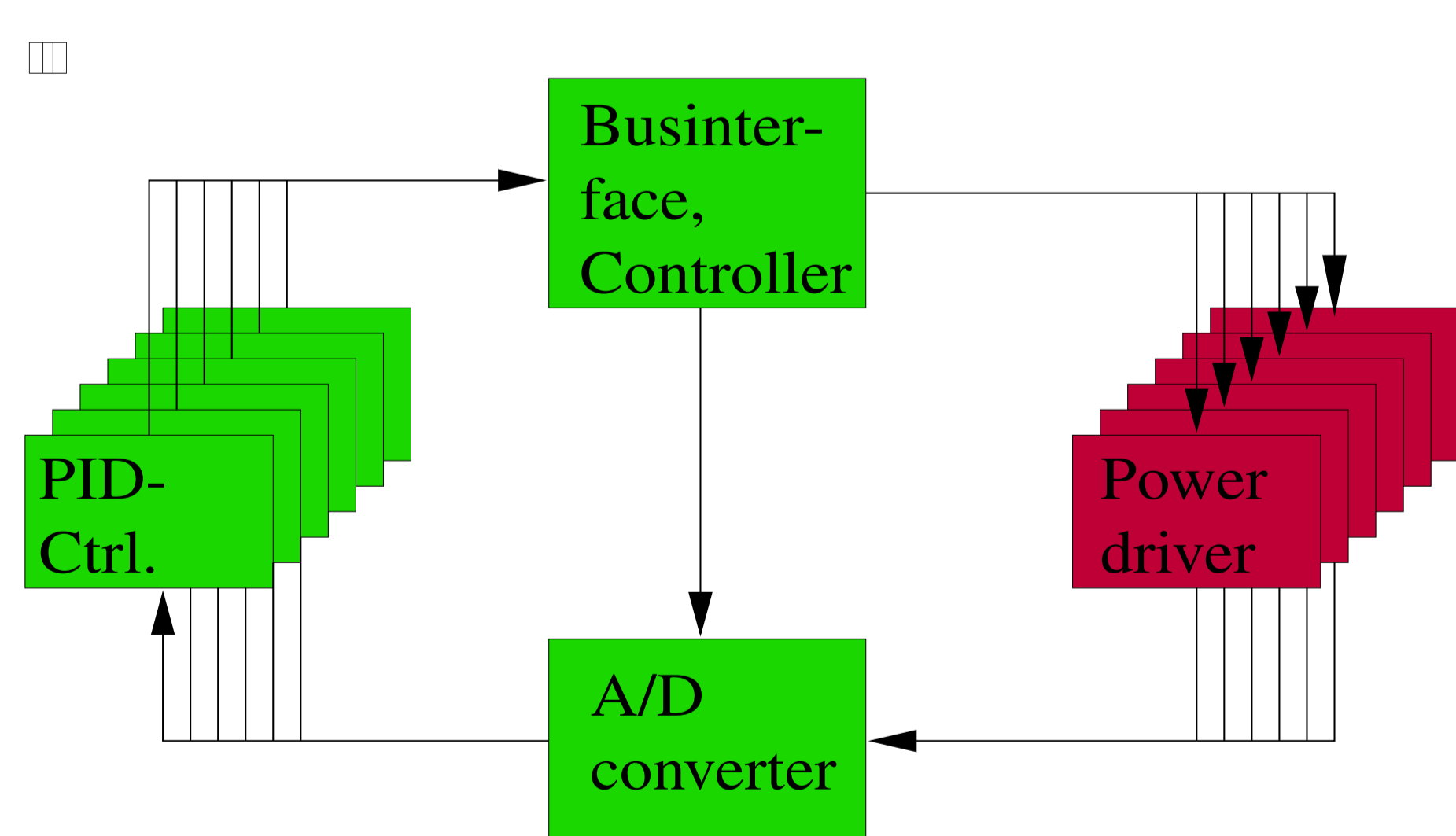

### PWM Current Control Loop

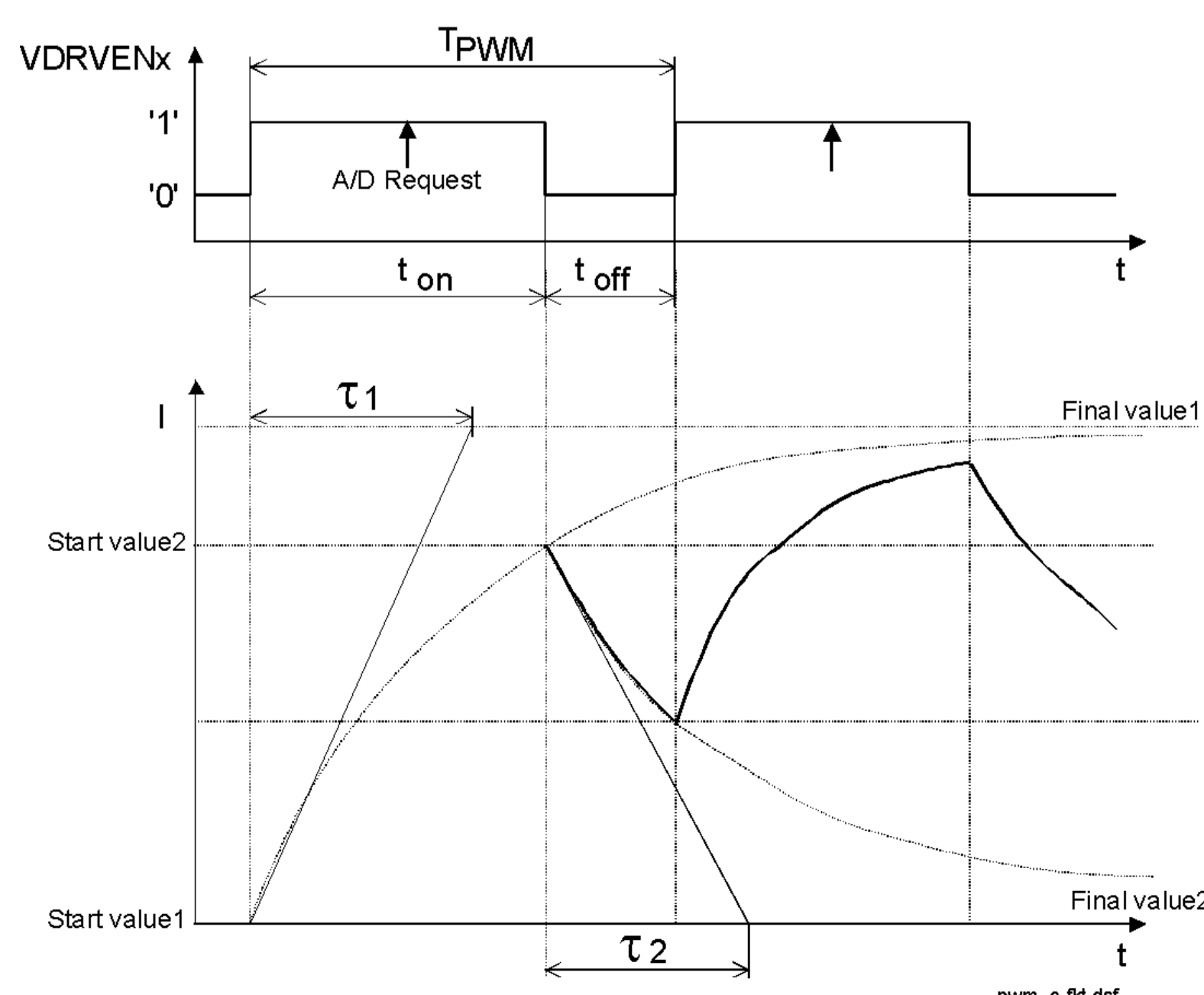

Basic Principle of Pulse Width Modulation (PWM)

## Results...

### PWM current regulation from 0 to 1 A

- ☐ Current of a constant coil
- ☐ Current of a valvemodel

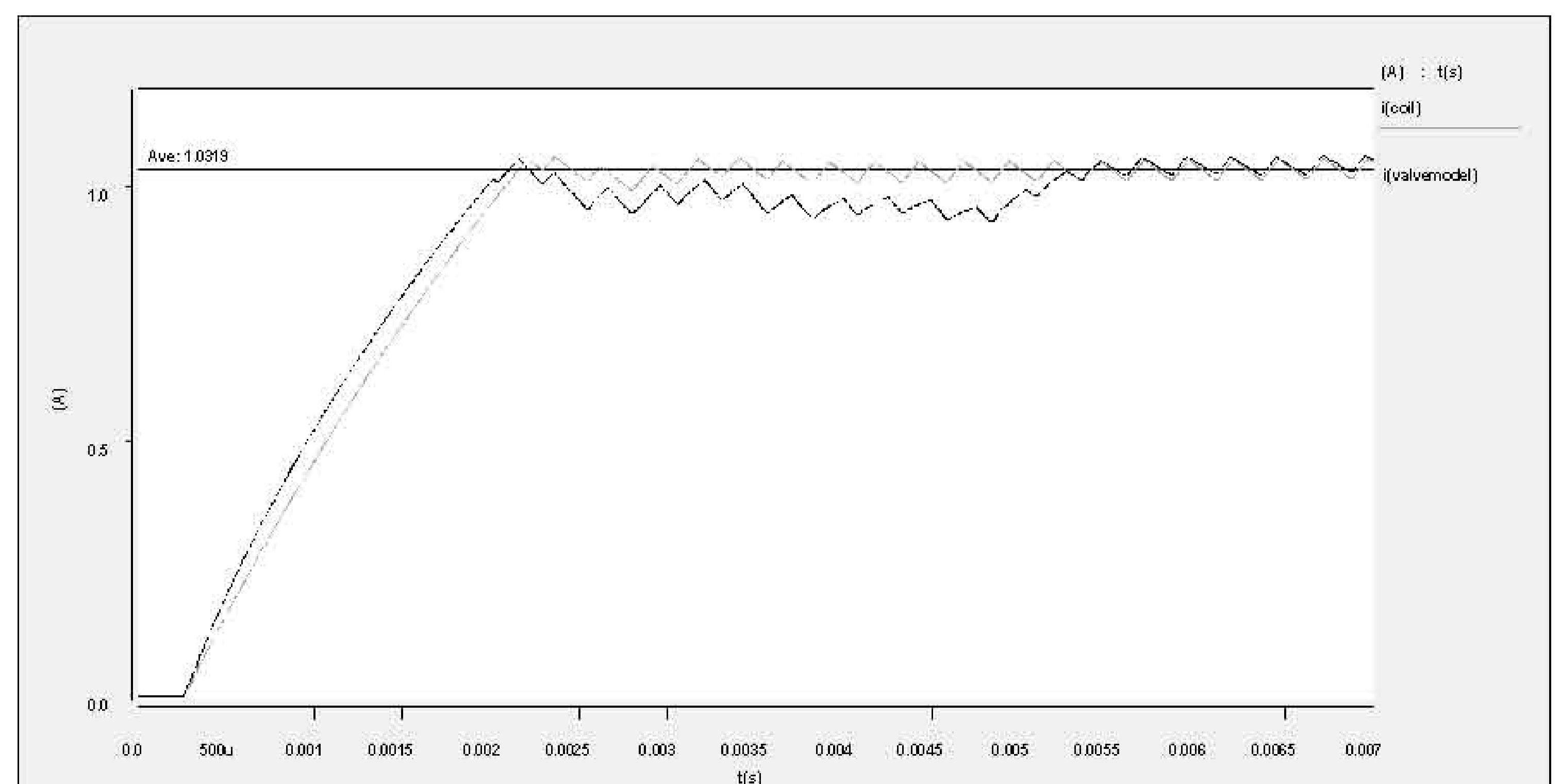

# Study of a Mechatronic Valve Model for the Automotive Industry

Christian Meise<sup>1</sup>, Peter Oehler<sup>1</sup>, Stefan Beitschuh<sup>2</sup>  
Wolfgang Fey<sup>1</sup>, Günter Schmitz<sup>2</sup>

<sup>1</sup>Continental Teves AG & Co. oHG,

<sup>2</sup>Aachen University of Applied Science (FH-Aachen)

## **Abstract**

The complexity of systems in the Automotive Industry increases day by day. Due to this, and the fact that modern products are based on advanced elements like Embedded Systems, which cannot effectively be designed without simulation techniques, motivates the development of a mechatronic valve model. This model was used to support an ongoing design project of a Mixed Mode IC for controlling valves.

## **1. Introduction**

Simulation Systems are often 'State of the Art' in modern development departments. Engineers use these kinds of tools in their development flow to avoid building real hardware. This shortens development time and decreases development cycles. This results in big benefits regarding the time to market aspect, which also becomes more and more important in the automotive industry. New products have to be developed and launched in shorter development periods. Another aspect of using virtual models and simulation techniques is an easier communication flow between different departments inside a company. These departments can discuss technical issues by using results from their simulations. To exchange real hardware with simulation techniques, one has to make sure that the models used can cover all relevant details. This is a significant fact also in modern system simulation projects with large simulation scenarios. Engineers tend to abstract a model to get better simulation performance. This becomes more and more important, due to the increasing complexity of the simulation scenarios used. All of these benefits motivated the start of a mixed signal IC design on advanced simulation activities at Conti Teves. Models of the IC and the additional application circuits, such as valves, are generated. The developed model of the analog valve is a good example of a compromise between requirements regarding performance and physical accuracy. Our engineering team decided to split the mechatronic valve model into different domains, such as mechatronic, hydraulic and magnetic domains. The concept is shown in Figure 1. Further usage and development changes can be improved from different development teams. The in-build ability of the Saber Simulator for describing different physical domains was a great help during the development phase of this project.

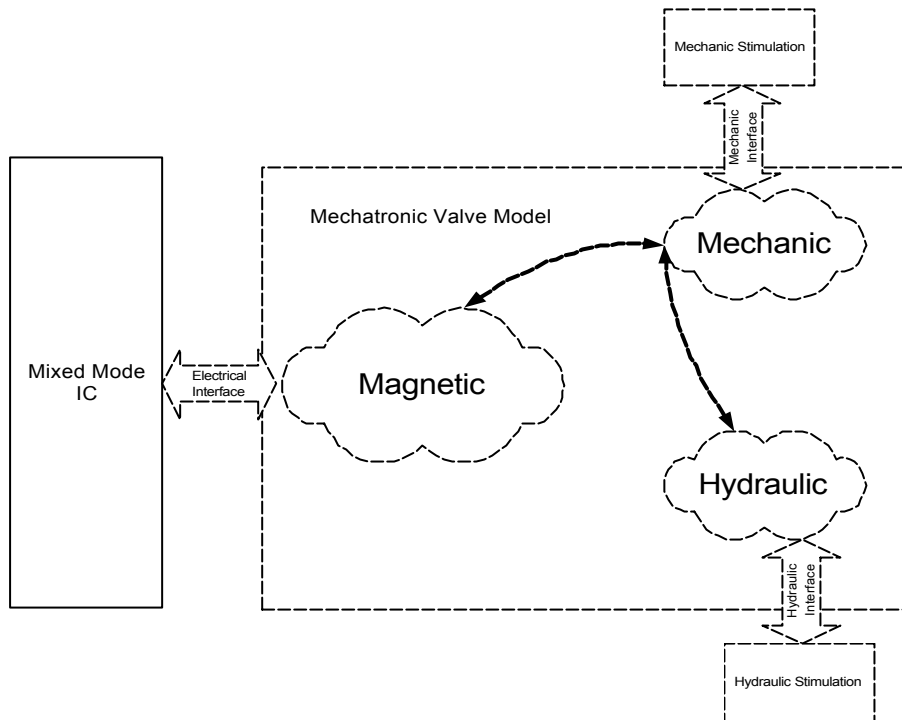

Figure 1.

## 2. PWM Current Control Loop for Analog Valves

One important block of the developed IC is the control mechanism for the valve positions. The positions are controlled by regulating the currents through the valves. The concept used to control the current through the valve is a Pulse Width Modulation (PWM) Controller. This controller sets a specific current by generating current pulses of varying width. The resulting current through the valve is dependent on the pulse width. The current is measured indirectly by measuring the voltage across a specific resistor in the actual current path. This measured value will be fed back into the controller to control the current by varying the pulse width. The concept of this control system is shown in Figure 2. We decided to build the controller with a digital PID filter in combination with an A/D converter. A Point of interest is the nearly completed digital implementation of the controller loop. The only mixed signal blocks are the A/D converter and the PWM valve output power stages. All other parts, including the PID controller, were designed as digital blocks. The usage of simulation techniques speed up the design phases dramatically. For example, all coefficients for the digital filter were found by simulation techniques. This saved several iterations with real silicon. Especially for Embedded Systems, simulation is an important technology, because it is not effective to build a discrete equivalent in hardware for each system. Therefore, a virtual representation is essential during development phases.

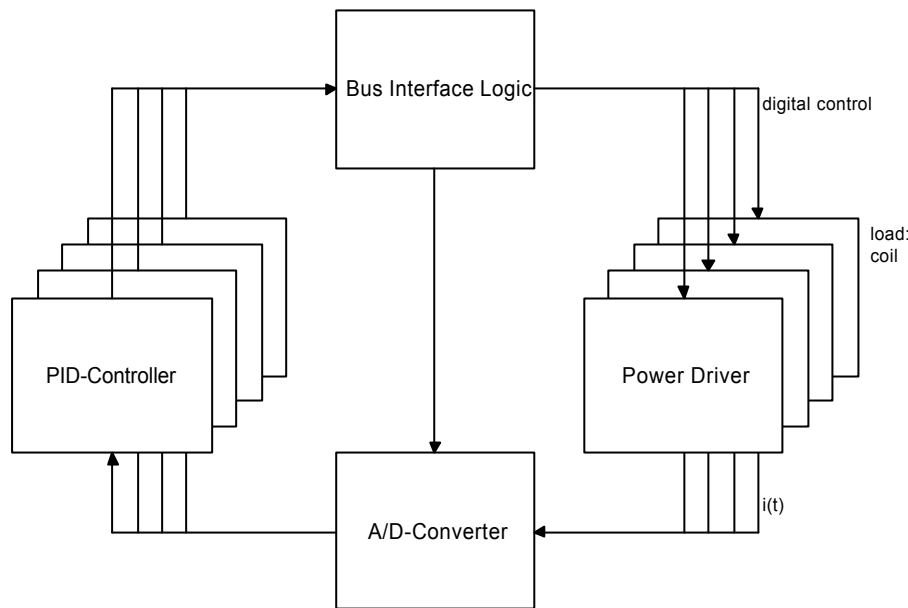

Figure 2.

### 3. The Mechatronic Valve Model

A simple representation of a valve is a combination of a coil in series with a resistor. This model is good enough for getting rough results in testing basic concepts. In order to find information for design decisions, more physical effects have to be taken into consideration. Switching a valve is not linear like a poor coil resistor combination is. The existence of an iron core, and changes of the geometry of the core by mechanical movements inside the valve during switching, changes the inductivity of the valve. This causes some nonlinear effects. Also, the hydraulic and the thermal effects are system relevant for design decisions of a complete controlling system. To help engineers coming from different disciplines, who are working together on one project, the steering team decided to implement the valve by splitting it into its different physical domains. Thus, the valve was implemented from a combination of a mechatronic, a hydraulic, and a magnetic block. The construction of each block was done with respect to the different 'views' of the engineering teams. Therefore, physical attributes like the inductance are not given explicitly by value. It is a result of a combination of geometric parameters, which can be taken directly from a blueprint. Each parameter in a block is declared and initialized in the header of the model and settable per text-editor or with SaberSketch. At this state of the model, there are min. 80 parameters. This was the second reason for splitting the Valve Model in three domains: The magnetic domain, the mechanic domain and the hydraulic domain (figure 3).

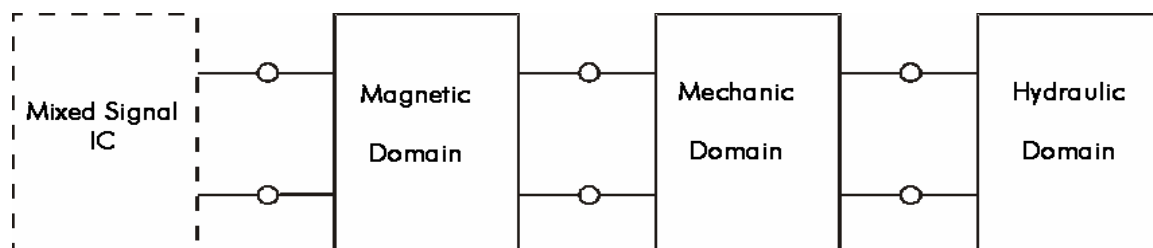

Figure 3. Summary of the model

### 3.1 The Magnetic Domain

The magnetic domain (figure 4) is classified in four components: A coil, two magnetic resistances and an air gap. The function of the magnetic domain is to transfer the control current into the magnetic force. This is achieved by the coil model converting the supplied current into a magnetomotive force. If eddy currents have to be considered in the magnetic circuit, the internal resistance of the coil model is set to zero and an external resistance is assigned instead. Connecting inductive/resistive elements to the magnetic coil, it is possible to simulate eddy currents. The magnetic circuit consists of many different components, which are represented in this model with two magnetic resistances. The magnetic flux spreads into sub-ranges of the magnetic actuator on relatively large cross-sectional areas. In the normal operating range, these areas will be less saturated. Other sections of the magnetic path will have saturation effects depending on the air gap, magnetic force and the resulting magnetic flux. Partitioning the domain into a saturated and an unsaturated component doesn't correspond exactly to reality, but it is accurate enough for this application. Additionally, this design offers a large flexibility to parameterize the model.

The model of the air gap transforms the magnetic values in mechanical values. This model calculates the force at the armature, and is dependent on magnetic flux and gap. The magnetic resistance as a function of the air gap, and thus a reaction to the magnetic circuit is simulated. The armature movement has an effect on the electrical domain caused by the magnetic circle. In an abstract, the magnetic domain is able to simulate the magnetic circle, the armature reaction, and possible eddy currents.

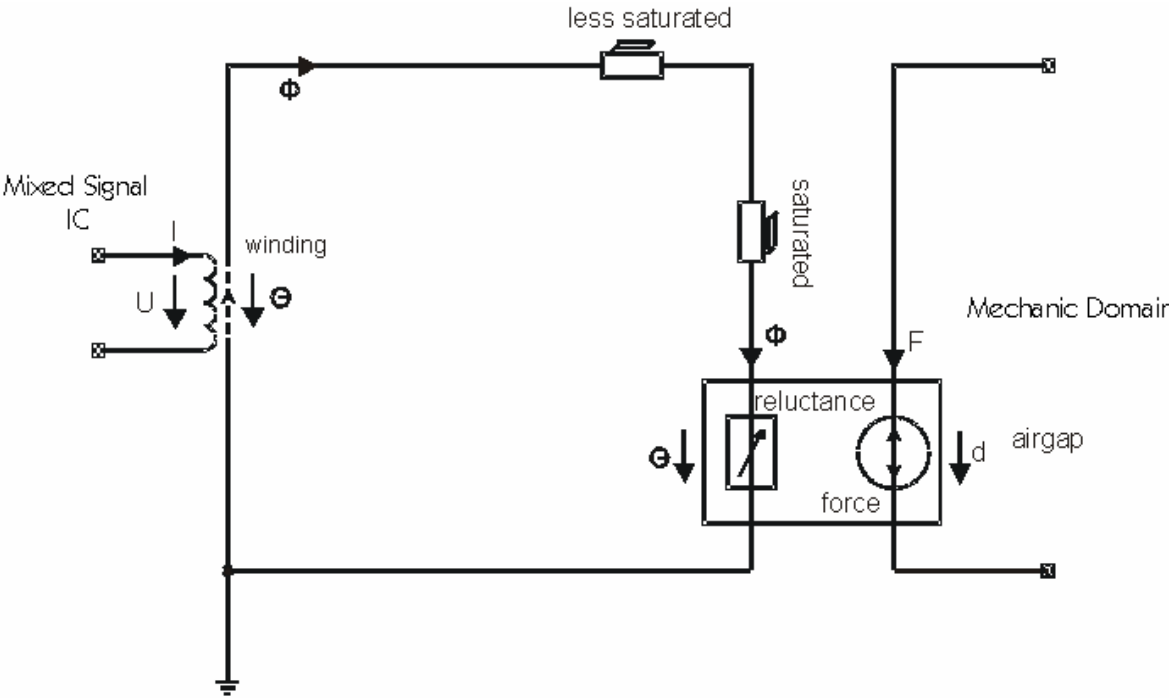

Figure 4. The Magnetic Domain

### 3.2 The Mechanic Domain

The mechanic domain represents the link between the magnet (figure 4) and the hydraulic domain (figure 6). The armature is connected to the tappet which controls the flow of the medium (hydraulic oil) at the control opening. A damping is used to simulate that the armature is surrounded by the medium. The friction of the armature at the guidance surfaces depends also on the medium. The damping and the friction are regarded in this model and temperature dependence is provided for them. There have been many problems with the friction. Is this model not programmed very precisely the domain gets very susceptible to numerical instabilities. The biggest problem exists when there are more than one friction elements in the model and two or more of them stick. Until the breakaway friction force is reached, the simulator can not decide which of these models absorb more energy. By optimizing the domain it was possible to neglect some frictions and work with only one friction. Transition from stiction to sliding friction often delivers numerical instability because the force at the body or rod will change discontinuously. A numeric formula which describes this transition reduces the numerical instability. It is very important to use a model which operates with this conclusion.

As the armature is limited in its motion, different contact points are simulated by hard stops. The armature is held by a spring in zero position at the control opening. For stability reasons the reduced mass and the mass of the armature are combined in the model. The model has to be able to represent different valve designs. As the spring washer affects the magnetic force and the gap between armature and pole surface it has to be inserted between armature and pole surface. The displacement of this disk is limited and the coefficient is not constant, therefore the model of this spring had to be extended. To obtain a minimum length the model is extended with a spacer and a hard stop. With the characteristic curve from the original spring washer a cubic equation is defined for the coefficient.

When no magnetic force is delivered by the magnetic domain, the valve will rest on the control opening. As described above this is achieved by a hard stop. Changing forces of the medium to the armature are regarded in the hydraulics domain and are transferred to the mechanic domain. The magnetic domain delivers the length of the air gap and the force which is provided by the air gap. These values are “recursive” because the mechanic domain is connected to the hydraulic domain and both of them give a reaction to the air gap. Therefore a reaction from each of these domains has a reaction at the electrical part of the magnetic domain.

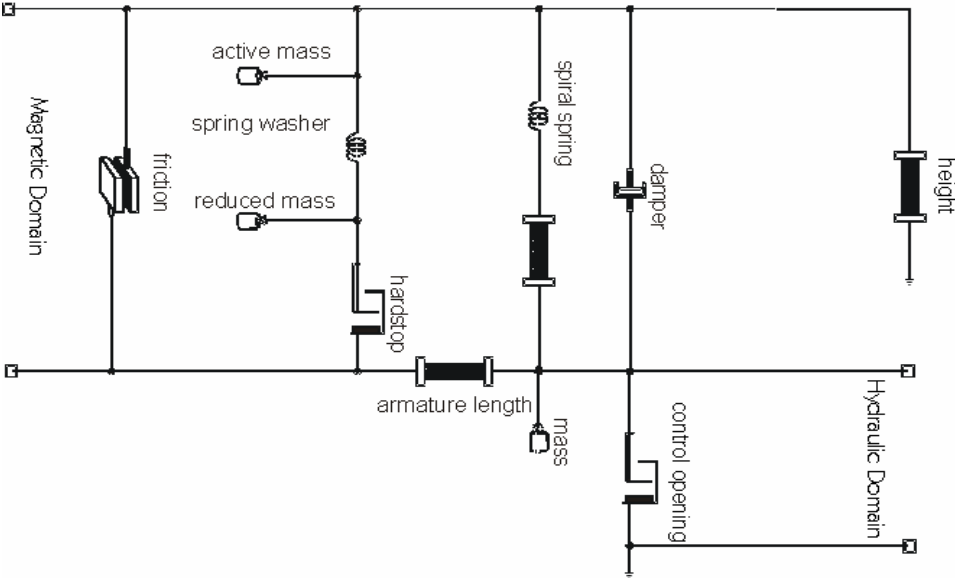

Figure 5. The Mechanic Domain

### 3.3 The Hydraulic Domain

All components of the system that have an influence on the medium flow are included in the hydraulic domain. The friction and absorption, which are caused by the medium in the mechanics, are carried out in the mechanical domain.

In order to get an easily usable model, we have defined three sections: The hydraulic pump section, the valve section, and the consumption section. Various versions of the valve are realized by splitting the structure of the pump section and the consumption section in three parts. Neutral volumes and the compressibility of the medium are implemented with accumulators. Constant pressure sources simulate the pressure in the pump section and the counter-pressure in the consumption section. Hydraulic lines are used for simulating the inlets, as well as different cross-sectional changes.

In principle, this model of a hydraulic line has parameters of length, diameter and coefficients, which describe the behavior of laminar and turbulent flow. The model thus influences the hydraulic flow and the drop in pressure. A flexible adjustment for different designs and different types of valves is possible with this structure. Different orifice geometry can be depicted by the valve model used. The configurations are simulated with characteristic diagrams measured at the prototypes.

The hydraulic domain is connected with the mechanical domain. Only the mechanical position of the valve is given by the mechanical domain because the standard valve model, which depends on a characteristic field, is not able to give a feedback about the force. Two models are needed to give adequate information about the forces at the valve which influence the model. The force by the pressure at the valve surface is calculated by an additional “pressure  $\rightarrow$  force” converter. A new model has been generated to calculate the force which is generated by the medium flow through the orifice. It depends on different measurements which had been set in relation to each other because we have not found a way to measure this force directly. The complex forces at the valve-surface which are necessary for the model are simulated by these two models.

With these elements the hydraulic model offers the possibility to change the necessary parameters and to adapt to the real model, and can easily be adapted to different configurations of the valve.

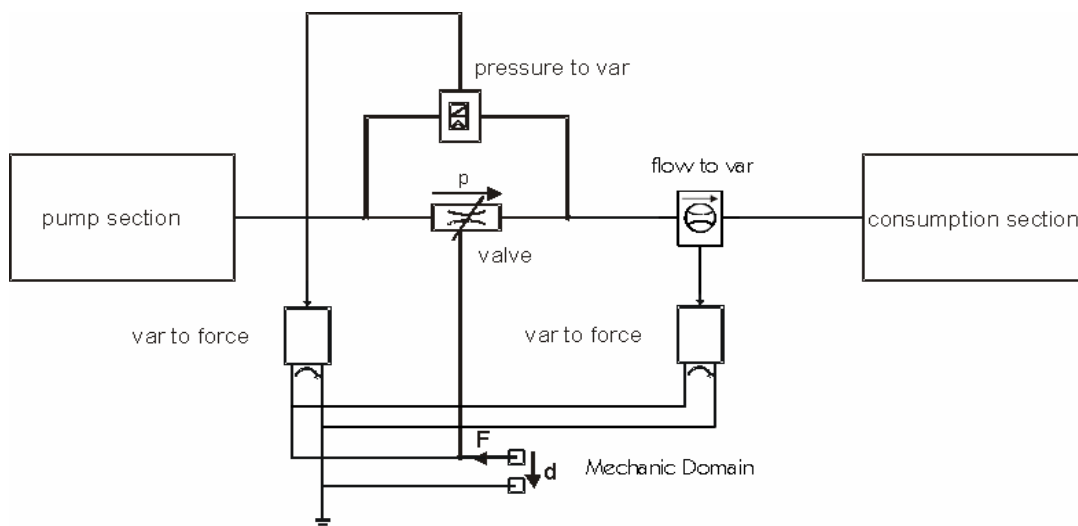

Figure 6. The Hydraulic Domain

#### 4. Simulation Results from an Ideal Valve Model versus the Mechatronic Valve Model

We have made some mixed-mode simulations with Verilog/Saber which show a big influence between using a simple coil, described by inductivity and series resistor, and the mechatronic valve model (see figure 3). We have simulated a closed loop as shown in picture 2. The filter coefficients for the digital PID controller were optimized for an ideal coil ( $L=17.5\text{mH}$ ,  $R_L=4.1\Omega$ ). Therefore, the dynamic regulation of a jump from 0 to 1A looks fine, no overshoot for example (current  $I(\text{coil})$  in figure 7).

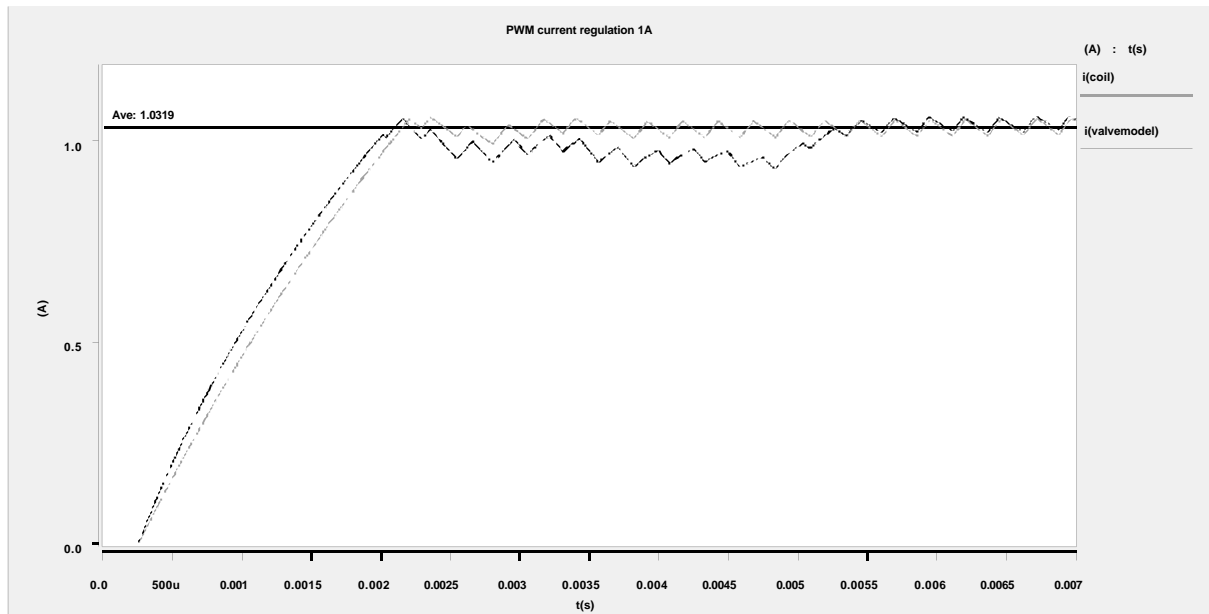

Figure 7

As you can see the time constant  $\tau=L/R_L$  for switching on the valve is similar to the ideal coil, the slope of current in both curves are close together. But the mechatronic valve model has no ideal e function (resulting from the iron core which causes some saturation effects). For an ideal coil the time constant for switching on or switching off is the same. Even this is not true for a valve, because of the iron core.

The mechatronic valve model is up to now parameterized in such a way that we do not see any dip when switching on or off the valve caused by the moving of the valve anchor. But this movement still changes the inductivity of the coil, which disturbs the closed loop: The current regulation for the mechatronic valve model is not stable until  $t=5.5\text{ms}$  in picture x. After that, the stability of mechatronic valve model and ideal coil are comparable.

Both, nonlinearities and armature movements, are the reason why we can see such a big impact on the behavior of the regulation of the current control loop real versus ideal valve model. These results show that it is not possible to optimize filter coefficients for a digital PID controller using only a simple coil model. For worst case it is yet possible that filter coefficients which are chosen in that way, cause an unstable current regulation of a valve.

#### 5. Conclusion

We are able to show the abstraction of systems is not always the key to success for realistic results. Often, physical side effects are part of technical solutions. Models have to take into account these effects, since as are relevant to the system functionality.



## References

Schmitz, G., Pischinger M.: "Mechatronische Simulation eines EMV- Aktuators", TransMechatronik, Entwicklung und Transfer von Entwicklungssystemen der Mechatronik, Paderborner Workshop Transmechatronik, 24.6.1997, Tagungsband ISBN 3-931466-22-1

Schmitz, G., Altherr, M., Hofmann, O., Pischinger, M., Kather, L. van der Staay, F.: "Anwendung moderner Simulationstools für die Entwicklung eines elektromagnetischen Ventilaktuators", ", 2. Workshop TransMechatronik, Aachen, 26.5.98, Tagungsband ISBN-3-931466-37-X

Schmitz, G., Pischinger M.: "Effiziente Entwicklung von magnetischen Aktuatoren durch den Einsatz mechatronischer Entwicklungstools", 18. Tagung "Elektronik im Kraftfahrzeug", Haus der Technik, 16.-17.06.1998, München

Schmitz, G., van der Staay, F., Kather, L., Boie, C., Kemper, H.: "Entwicklung eines elektromechanischen Ventiltriebs mit Hilfe mechatronischer Entwicklungswerkzeuge", Tagung "Variable Ventilsteuerung", Haus der Technik, 28.-29.03.2000, Essen

Schmitz, G. (Hrsg.): "Mechatronik im Automobil", expert Verlag, ISBN 3-8169-1839-5

Meise, C., Oehler, P., Beitschuh, S., Fey, W., Schmitz, G.: "Study of a Mechatronic Valve Model for the Automotive Industry", Saber User Group Meeting, 14.11.2001, München

D. Gospodaric, Z. Jajtic: "Einsatz moderner Methoden zur dynamischen Simulation von Aktuatoren am Beispiel eines Regelventils für Fahrwerksdynamik", 2. Tagung "Mechatronik im Automobil", Haus der Technik und FH Aachen, 15.-16.11.2000, München

J. Schuller, P. Brangs, R. Rothfuß: "Entwicklungsumgebung für die Fahrdynamikregelung DSC", 2. Tagung "Mechatronik im Automobil", Haus der Technik und FH Aachen, 15.-16.11.2000, München